

NAAC Criterion 4: Infrastructure and Learning Resources

4.4 IT Infrastructure

4.4.3: Available bandwidth of internet connection in the Institution





PES
INSTITUTE OF
MEDICAL SCIENCES
& RESEARCH

PES Institute of Medical Sciences & Research

Kuppam- 517 425, Chittoor Dist., Andhra Pradesh

Tel: 08570 - 277999, 277799, 277666

Email: principal@pesimsr.pes.edu Web: www.pesimsr.pes.edu

Additional information



Ref : PESIMSR/ESTAB/ ²⁵⁷⁸ /2023-24

Date : 09.08.2023

IT POLICY

1. Purpose

The purpose of this document is to outline the IT infrastructure policy and usage

2. Scope

These procedures apply to all of PESIMSR's in-house servers and internal network equipment supporting PESIMSR's file systems. It also covers the general physical security at PESIMSR.

3. Introduction / Background

To ensure a secure IT environment, it is necessary to appropriately control and restrict access to sensitive file systems and servers on which they reside. Individual user accounts on core servers as well as system administrative accounts supporting these applications must be adequately controlled to prevent unauthorized access from security vulnerabilities.

4. Tools / Environment

Approvals: Internal IT Ticketing based Process Tool, Email.

Monitoring Tool: Ping/RealVNC/Network Switch monitoring tool.

Log Server: Sophos Integrated Gateway Level Log server.

Security Devices: Sophos NextGen Firewall.

Security Services: NextGen Firewall with App/Web/IPS/IDS/WAF/ATP Subscription enabled services.

Security Tools: OVAS, Nmap.

Virus Protection: Seqrite End Point Protection {Quickheal}

Access Control: Extended Named ACLs at Multi-Layer Core/Distribution Switches.

Data Backup: Scheduled SQL Backup server.

Power Supply: UPS/DG.

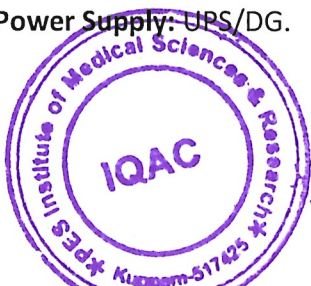

Dr H R KRISHNA RAO
MBBS MS(Anatomy)
DEAN & PRINCIPAL
PES Institute of Medical Sciences & Research
Kuppam-517425 Chittoor Dist, A P
Mobile -9391833752

5. OS and Internal Network Security Processes

5.1. Server OS Security Measures ("Hardening" Practices)

- i. Local Administrator account name shall be changed to PESIMSR Server standard
- ii. Guest accounts shall be disabled
- iii. Only necessary services shall be installed in the Servers
- iv. Servers shall be patched with the latest critical security updates before joining the domain. Service Packs shall be applied only with the approval of the IT Services In-charge
- v. Unless exempted by the IT Services In-charge, all Servers shall have antivirus software installed and configured as per PESIMSR's antivirus installation procedures
- vi. PESIMSR is committed to network security and has implemented industry standard security appliances from Sophos®. PESIMSR shall continue to protect the network from external and internal threats and upgrade appliances as and when needed
- vii. Local server accounts and groups shall not be allowed unless necessary for the proper operation of the server.
- viii. The domain admin accounts designated as master accounts shall not be used as service accounts.
- ix. By default, only administrators shall be granted the privilege of logging into the Servers via remote desktops. This default configuration shall not be changed on any servers other than designated terminal servers for which remote user access is allowed.

Securing the File System- The data portion of the file system on the servers is secured and shall not be accessed by individuals. Only administrators shall have the rights to create and modify the file system in all the servers.



Dr H R KRISHNA RAO
MBBS MS(Anatomy)
DEAN & PRINCIPAL
PES Institute of Medical Sciences & Research
Kuppam-517425 Chittoor Dist,A P
Mobile -9391833752

5.1.1. Account Access Rights and Controls

- i. Read, write and execute permissions shall be limited to the system administrators and IT Services In-charge
- ii. On a quarterly basis, all server accounts shall be reviewed to ensure that no unauthorized accounts have been created and that all unnecessary accounts have been disabled or deleted. The review shall be approved by the IT Services In-charge
- iii. Passwords shall comply with the standard procedures. Shared passwords used for system and network administration shall be changed quarterly or whenever someone with access to operating system or internal network infrastructure is transferred or leaves PESIMSR.

EXCEPTION: NONE ALLOWED

5.1.2. File Share and Directory Restrictions

To ensure that the data on the Servers are intact and safe from unwarranted manipulation, file shares and directory structures for programs shall be determined and approved by the IT Services, In-charge

5.1.3. Database Restrictions

Any access to the PESIMSR resources like webserver, Authentication, Authorization & Audit (AAA) server, Mail server database, etc., shall be limited to the authorized system admin and the IT Services, In-charge.

5.2. Antivirus Protection

5.2.1. Antivirus Server Management

Seqrite Antivirus Endpoint and Management tool shall be used for centralized management and monitoring of virus protection for all computers and servers.

The server automatically synchronizes with Seqrite repository every day for updated virus definitions and pushes the updates when available.



Dr H R KRISHNA RAO
MBBS MS(Anatomy)
DEAN & PRINCIPAL
PES Institute of Medical Sciences & Research
Kuppam-517425 Chittoor Dist, A P
Mobile -9391833752

5.2.2. Desktops / Laptops / Servers

Seqrite Enterprise Server manages the antivirus software on all Windows computers and servers.

The Seqrite software scans and “shreds” infected files on a continual basis.

- I. As soon as Seqrite server downloads new IDEs (virus updates), the updates shall be pushed to all connected systems (servers and workstations).
- II. Every hour, remote workstations pull any new IDE.
- III. Access to Port no 25 (SMTP) shall be blocked in all the systems as SPAM mails can be generated
- IV. Faculty members and students who connect to the PESIMSR network, shall always
- V. have a valid anti-virus software installed in their systems

5.2.3. Hardware / Software Change Management

Approval of the IT Services, In-charge shall be required for changes to Servers and other internal network equipment that may affect in-scope servers, including:

- configuration setting changes (policies, access control lists) within the OS (server OS and other network devices)
- operating system software patches (server OS and other network devices)
- operating system software version upgrades (server OS and other network devices)
- hardware upgrades / firmware upgrades

5.3. Internal Network Device Access Controls

Passwords shall comply with PESIMSR’s policies and shall be changed for network devices (routers, switches, etc.) on a quarterly basis or whenever a network administrator is transferred or leaves PESIMSR.



Dr H R KRISHNA RAO
MBBS MS(Anatomy)
DEAN & PRINCIPAL
PES Institute of Medical Sciences & Research
Kuppam-517425 Chittoor Dist, A P
Mobile -9391833752

5.4. Firewall and Router Access

- I. Outbound traffic: Filtering shall be activated for all computers. Only certified and education related sites shall be allowed access . Only the IT Services, In-charge shall approve any additions or modifications to the list of allowed sites. For all other systems in the network, only http, https shall be allowed.
- II. Inbound traffic: Filtering of all inbound traffic and packets shall be allowed only through the firewall, if they are determined to be responses to outbound requests.
- III. Any other access shall be disabled

5.5. Remote Access

Remote access to any PESIMSR's infrastructure shall be restricted and controlled. Access shall be granted on need basis and through VPN (IPSEC/SSL) only. Mail shall be accessed through WebMail, Outlook and IMAP.

5.6. Security Monitoring & Data Security

5.6.1. Security Breaches / Incidents

IT Services Staff shall monitor / review operating system activity logs for possible security breaches. The Wi-Fi and wired networks shall be connected with the Sophos Gateway and the activities of the users shall be recorded for several days. In case of an attempt by any user to breach the security policy of PESIMSR, appropriate action shall be taken in order to avoid such future incidents

5.6.2. Vulnerability Assessments

IT Services Staff shall conduct quarterly vulnerability assessments. The results shall be reviewed by the peers and necessary steps shall be taken, if required.



Dr H R KRISHNA RAO
MBBS MS(Anatomy)
DEAN & PRINCIPAL
PES Institute of Medical Sciences & Research
Kuppam-517425 Chittoor Dist, A P
Mobile -9391833752

5.6.3. External Assessments

PESIMSR shall engage third-party security organizations to conduct an annual penetration assessment of the network to identify any exposures that may be exploited for unauthorized access, if required. The results shall be reviewed by the Admins and IT Services In-charge and actions shall be taken, if necessary

5.6.4. Data Security

- i. File servers and the storages shall be protected with a Firewall. These servers and storages are not accessible directly from any external network.
- ii. Access to Removable media such as pen drives, external hard drives, compact media shall be restricted, unless permitted by the Lab in-charge

6. Personal Integrity

System Admins and the IT Services, In-charge shall maintain confidentiality and shall follow professional ethics and protocols prescribed by the Institution.

7. Physical Security

The entire campus is monitored through CCTVs and each building is guarded by Security personnel 24x7. This provides adequate security to the IT infrastructure and only authorized persons shall be permitted in the Server rooms and restricted areas.

8. Power Backup & Air Conditioning

The Server rooms have two power backups – UPS and generator in the event of power failure. Systems in the labs and switches in all buildings including hostels shall be connected to a separate backup.

The Data Centre shall be maintained at $20 \pm 2^{\circ}\text{C}$.



Dr H R KRISHNA RAO
MBBS MS(Anatomy)
DEAN & PRINCIPAL
PES Institute of Medical Sciences & Research
Kuppam-517425 Chittoor Dist, A P
Mobile -9391833752

9. Physical Access Controls, Processes

9.1. Use of Access Control System

- i. All employees, contractors, vendors, and visitors shall have identification badges.
- ii. The issuance of permanent access to restricted data centres and server rooms shall be approved by the IT Services, In-charge. No temporary / emergency access shall be granted.

9.2. Granting Access

The Office of the Registrar issues identification badges to all employees to enter the buildings. Vendors and contractors shall obtain their entry pass from the Main Gate Security.

9.3. Monitoring New Access lists, Terminations, Modifications, and Restricted Area Usage

- i. Whenever a faculty / staff leaves the institute they shall obtain no dues form signed by the IT Services, In-charge.
- ii. On leaving the Institution, the concerned user's mail box and webserver account shall be frozen.
- iii. Fresh graduands shall be permitted to use the PESIMSR mail account until the Convocation, after which the mailbox shall be frozen.



Dr H R KRISHNA RAO
MBBS MS(Anatomy)
DEAN & PRINCIPAL
PES Institute of Medical Sciences & Research
Kuppam-517425 Chittoor Dist,A P
Mobile -9391833752

10. SOFTWARE ASSETS AND OPEN-SOURCE RESOURCES

The generic software assets like the operating system license, office utilities, antivirus shall be centrally managed by the IT Services Facility. Every PESIMSR computational asset (Server, Desktop, Laptop) shall have a genuine licensed operating system either in the form of OEM pre-loaded or in the form of paper license. PESIMSR has a campus agreement with Microsoft and has Dreamspark premium for individual Schools.

Lab-specific software tools shall be procured by the concerned School and the license shall be maintained by them. Software that are utilized by multiple Schools shall be centrally hosted in the Server.

PESIMSR promotes open-source tools and hence one server that has a repository of open source tools shall be maintained in the server.

11. SERVICE BACKUP AND RISK MANAGEMENT

- i. PESIMSR has backup servers for critical servers like Web, Asset, etc, Servers in order to provide continuous service without disruptions.
- ii. The backup / replication shall be available in the server and at the storage end
- iii. In case of any fault, backup server shall be used till the fault is rectified
- iv. Annual maintenance contract shall be maintained with vendors for quick restoration
- v. All login credentials and a copy of the settings shall be available with the IT Services, In-charge





Dr H R KRISHNA RAO
MBBS MS(Anatomy)
DEAN & PRINCIPAL
PES Institute of Medical Sciences & Research
Kuppam-517425 Chittoor Dist., A P
Mobile -9391833752

12. PESIMSR Gateway /Core /Distribution Device Details.

PESIMSR- Sophos XG 430 Firewall Features

- Recommended for 1500+ User Network
- Threat Protection Throughput: 5.4 Gbps
- Site-to-Site VPN Tunnels: 5400
- Concurrent Sessions: 10,000,000
- vision Number: 2
- Appliance Only -- Includes 90-Days of Firmware Updates

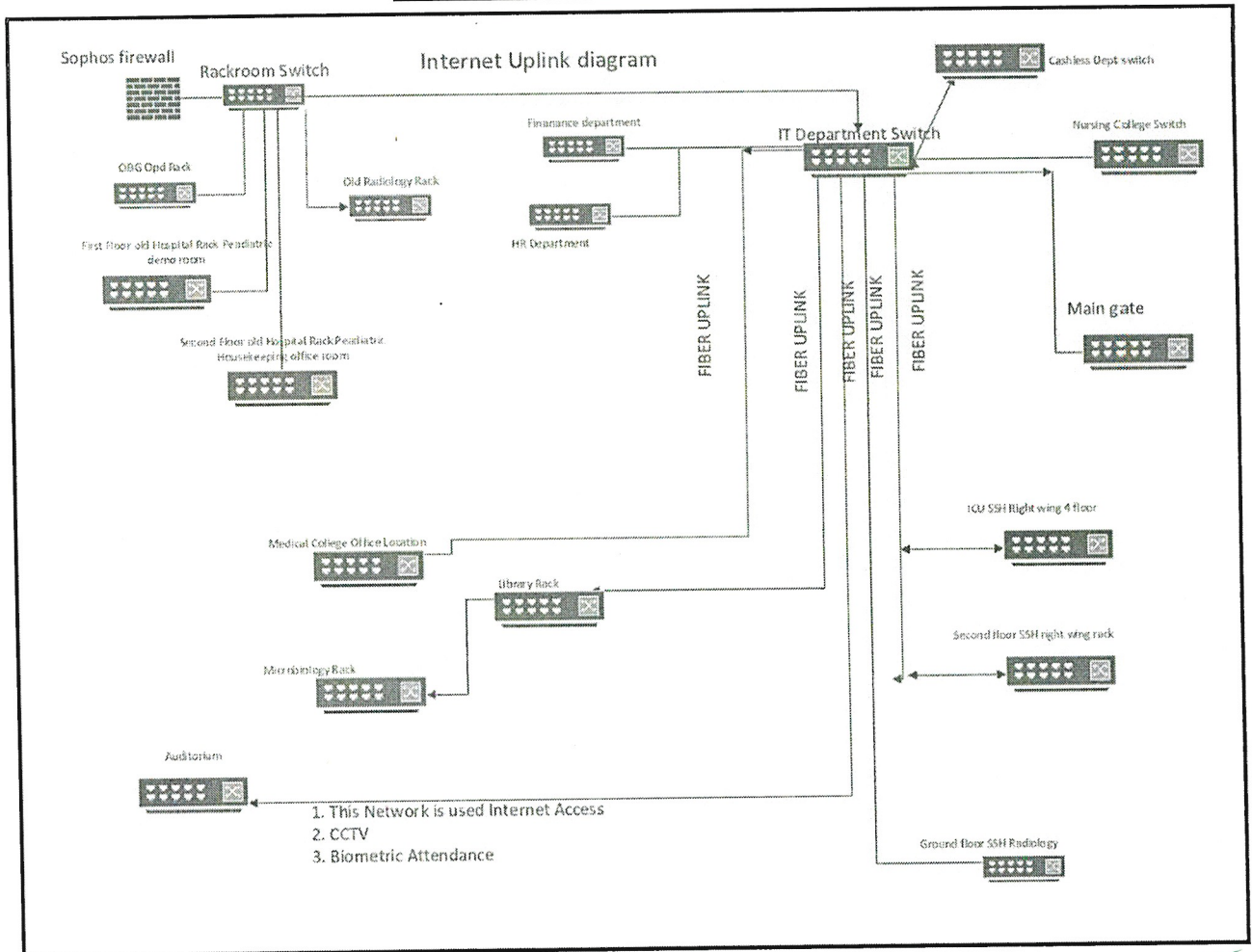
PESIMSR CAMPUS DIAGRAM



Crav
Dr H R KRISHNA RAO
 MBBS MS(Anatomy)
 DEAN & PRINCIPAL
 PES Institute of Medical Sciences & Research
 Kuppam-517425 Chittoor Dist, A P
 Mobile -9391833752